

3M™ Infrared Thermometers

Non-contact temperature measurement devices spot trouble quickly, safely and accurately



3M *Innovation*

When surface

Reduce maintenance costs

temperature is

Increase product/process quality

critical & contact

Increase safety

is not an option



IR-500



IR-750/950



IR-1100/1400/1400IS



IR-60L2/60CFO



IR-60EXPL2/60EXCFO

3M™ Infrared Thermometers—the fast, safe and accurate way to "spot" trouble.

Applications

Electrical Maintenance

- Locate over-temperature conditions caused by defective circuit breakers, overload conditions or poor electrical connections
- Monitor electric motors
- Locate loose wire connections
- Diagnose nuisance tripping of circuit breakers
- Locate defective ballasts within fluorescent fixtures

Mechanical Equipment Maintenance

- Monitor furnace exteriors
- Test heat exchangers, steam traps, air vents
- Identify refrigeration problems
- Check thermal insulation

Car/Truck/Fleet Maintenance

- Locate radiator core blockages
- Identify misfiring spark plugs
- Monitor electrical components
- Diagnose low voltage batteries

Transportation

- Monitor road surface temperature for icing conditions
- Maintain asphalt temperature during preparation and application

Food Safety*

- Audit storage temperature
- Maintain process temperature

Household*

- In the kitchen
- In the garage
- In the workshop

*Infrared thermometers are approved for use with food by the U. S. Food and Drug Administration (FDA).

When your job calls for leading edge temperature measurement technology, 3M provides the solution with the family of 3M Infrared Thermometers. These units provide a fast, easy and accurate way to measure a wide range of temperatures at a safe distance. You can monitor equipment more closely, more accurately, and more often — and spot trouble before it leads to costly malfunction and repair.

Choose the thermometer that's right for your job

Product	Laser Sighting	Distance-to-Spot Ratio	Alarms	Data Logs	Emissivity	Maximum Temperature
IR-500	Single spot	6:1	-	-	Fixed	500°F (260°C)
IR-750	Single spot	12:1	-	-	Fixed	750°F (400°C)
IR-950	8 point circle	12:1	-	-	Fixed	950°F (545°C)
IR-1100	8 point circle	30:1	HI-LO	12	Adjustable	1100°F (600°C)
IR-1400	8 point circle	50:1	HI-LO	12	Adjustable	1400°F (760°C)
IR-1400IS	8 point circle	50:1	HI-LO	12	Adjustable	1400°F (760°C)
IR-60L2	17 point circle	60:1	HI Only	-	Adjustable	1600°F (870°C)
IR-60CFO	17 point circle, Close focus	50:1	HI Only	-	Adjustable	1600°F (870°C)
IR-60EXPL2	17 point circle	60:1	HI-LO	100, Software	Adjustable	1600°F (870°C)
IR-60EXCFO	17 point circle, Close focus	50:1	HI-LO	100, Software	Adjustable	1600°F (870°C)

Does your job require NIST or DKD compliance? Be sure to order your IR-750, IR-950, IR-1100, IR-1400, IR-60L2, or IR-60EXPL2 with certification (NIST or DKD).

8 Point Circle



17 Point Circle



The 8 Point and 17 Point lasers form circles to show the appropriate area being measured; a single laser spot shows the center of the measurement area.

Simple, One Button Operation for General Use

The one button operation of the IR-500, IR-750 and IR-950 offers the ultimate in ease of use for fast, accurate temperature measurement. With single-point laser sighting, their point-and-shoot operation and back-lit LCD displays make them user friendly, with minimal training required for use. These units are lightweight yet durable enough to withstand daily use. Pick the unit that fits your application based on your measuring distance and the temperature range of the objects you wish to measure.

3M™ IR-500, IR-750, IR-950 Infrared Thermometer

The IR-500 is pocket-sized which makes it convenient to carry during daily maintenance checks. With a 6:1 distance-to-spot ratio, it is best used within 4 feet of the object and has a temperature range of 0° to 500°F (-18° to 260°C).

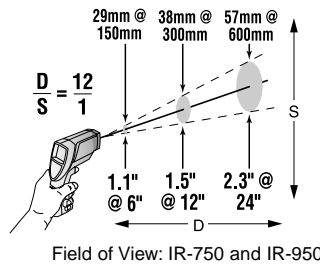
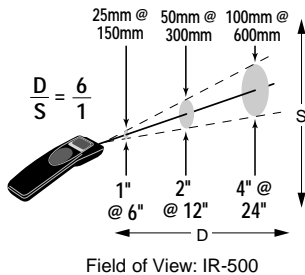

Check cylinder heads, heating and cooling systems, and scan radiators for blockage.

The 3M IR-750 and IR-950 Infrared Thermometers cover the basics of temperature measurement in industrial environments. They both feature a 12:1 distance to spot ratio that allows more flexibility in measuring hard to reach

objects. The ability of the IR-750 and IR-950 to read sub-zero temperatures add to their versatility. The IR-750 measures up to 750°F (400°C), and the IR-950 measures up to 950°F (545°C).



Check for hot spots in electrical panels and circuit breakers, generators and gearboxes.



LCD Display for IR-750 and IR-950

Alarms and Data Storage for Commercial Temperature Monitoring

Invaluable tools for commercial use, the IR-1100, IR-1400 and IR-60L2 allow you to set alarms for hot spot scanning, plus the IR-1100 and IR-1400 eliminate the need for a clipboard with data storage capabilities. Their sub-zero to high-temperature ranges and adjustable emissivity, along with their high distance-to-spot ratios give you the accuracy you need in a commercial environment. Pick the unit that fits your application based on your measuring distance and the temperature range of the objects to be measured.

3M™ IR-1100 and IR-1400 Infrared Thermometers

The 3M IR-1100 and IR-1400 Infrared Thermometers expand their measurement capabilities with the ability to store 12 data points to allow recall of the maximum, minimum, differential, average and last temperature readings. A scan mode with Hi-Lo alarms sounds when preprogrammed temperatures are registered. Accuracy is enhanced with a circular laser sighting and adjustable emissivity.

The IR-1100 features 8 point circle laser sighting, a 30:1 distance-to-spot ratio and a temperature measurement range from a low -25°F (-32°C) to 1100°F (600°C).

The IR-1400 features 8 point circle laser sighting, a 50:1 distance-to-spot ratio and a temperature measurement range from a low -25°F (-32°C) to 1400°F (760°C).

An optional accessory for the IR-1100 and the IR-1400 is the IR Probe, a Resistance Temperature Detector which plugs into the standard jack on these units and provides contact temperature simultaneously with noncontact temperature. Accuracy +/- 2°F Temperature Range: -13°F to 500°F.

For hazardous environments, the IR-1400IS is Factory Mutual Approved. It's rated Intrinsically Safe for Class I, Division I, Groups A, B, C, D. Class 1, Zone 0, AEX is IIC, T4 at 50C when used with 9v alkaline battery and it includes an approved external contact probe. The IR-1400IS allows you all the benefits of the IR-1400, with the additional feature of usability in potentially hazardous (explosive or flammable) locations. Many sites require that only Intrinsically Safe devices be used.



Store temperature measurements for more precise monitoring.

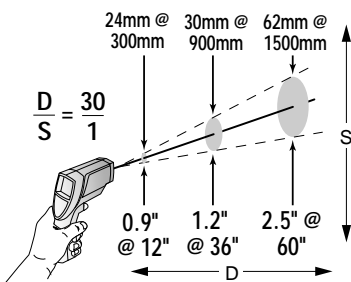

Field of View: IR-1100

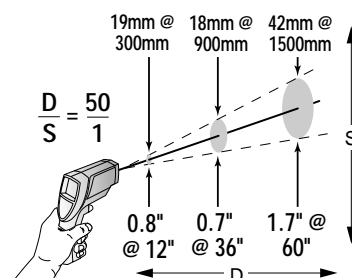

Field of View: IR-1400



LCD Display for IR-1100 and IR-1400

3M™ IR-60L2 and IR-60CFO Infrared Thermometers

The IR-60L2 and IR-60CFO measure from a low -25°F (-32°C) to a maximum 1600°F (870°C) with the increased accuracy of a 17 point circle laser sighting, adjustable emissivity and a Hi alarm for scanning. The IR-60L2 features a 60:1 distance to spot ratio. When your job requires a precision reading of a very small object at a distance, the IR-60CFO, with a close focus 50:1 distance to spot ratio, provides this added capability.

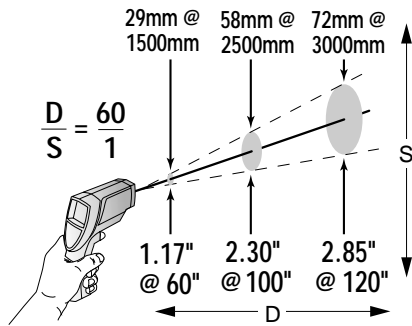

Field of View: IR-60L2 and IR-60EXPL2



IR-60L2/60CFO

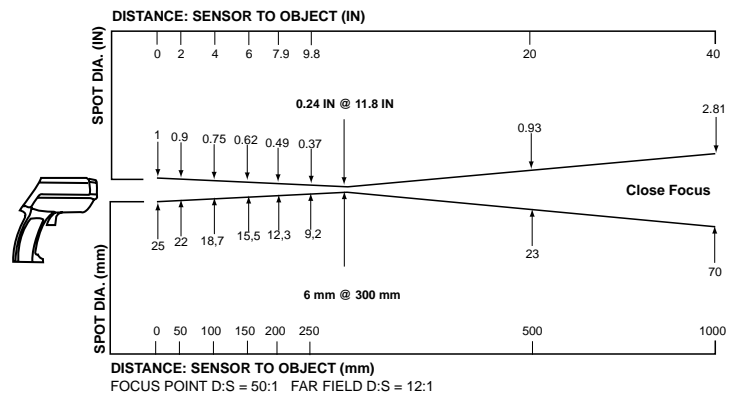

Field of View: IR-60CFO and IR-60EXCFO

The contact probe accessory, standard with the IR-1100, IR-1400, IR-60EXPL2 and IR-60EXCFO, allows contact measurement of reflective surfaces.

Laser Accuracy and Data Logging for Professional Temperature Monitoring

Ideal for data logging and trend analysis, these 3M Infrared Thermometers connect directly to your PC or printer for data download.

3M™ IR-60EXPL2 and IR-60EXCFO Infrared Thermometers

For the ultimate in data logging, the 3M IR-60EXPL2 and IR-60EXCFO Infrared Thermometers not only measure to a maximum 1600°F, but add the versatility of direct computer connection for data downloads or printing. Additionally, both units store up to 100 data points allowing for easy set-up of preventative maintenance programs. Accuracy is further enhanced with a 17 point true circle laser sighting, adjustable emissivity, and Hi and Lo alarm features. The contact probe accessory allows contact measurement of reflective surfaces. Lightweight, rugged and built to withstand use in industrial environments, the point-and-shoot operation and back-lit LCD digital/analog display make these units user friendly. Temperature measurement ranges from a low -25°F (-32°C) to a high 1600°F (870°C).

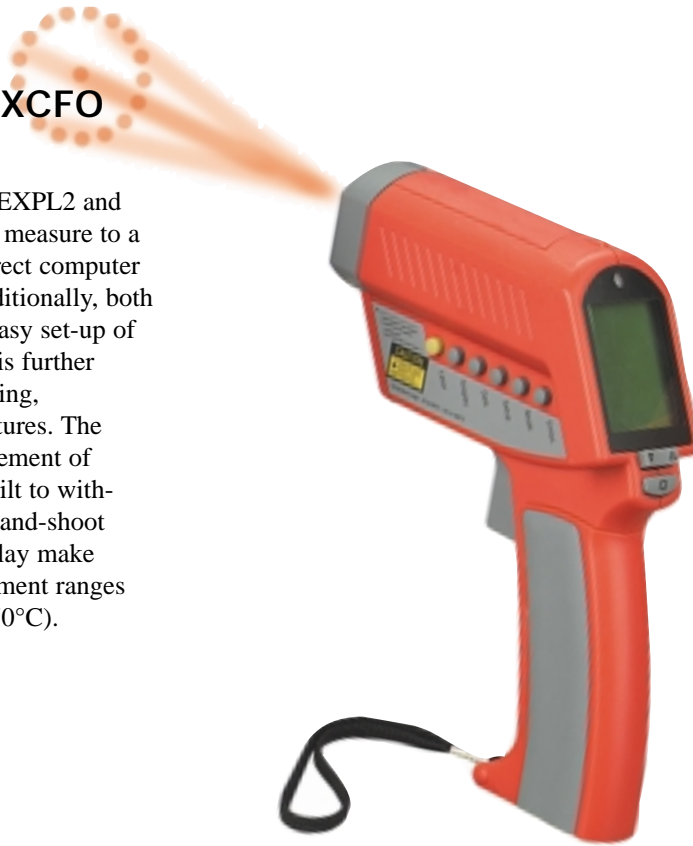

The IR-60EXCFO features a close-focus, 50:1 distance to spot ratio. The IR-60EXPL2 has a 60:1 spot ratio.



The 3M IR-60EXPL2 and IR-60EXCFO come standard with an RS232 cable, Windows-based software, power supply and contact probe.

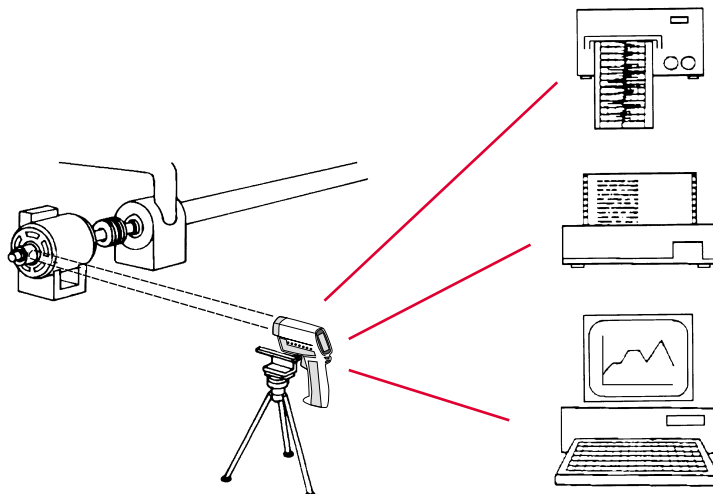

These units can mount to a tripod, where temperature data can be measured over an extended period of time and output directly to a chart recorder, printer, or PC.

Building Layout

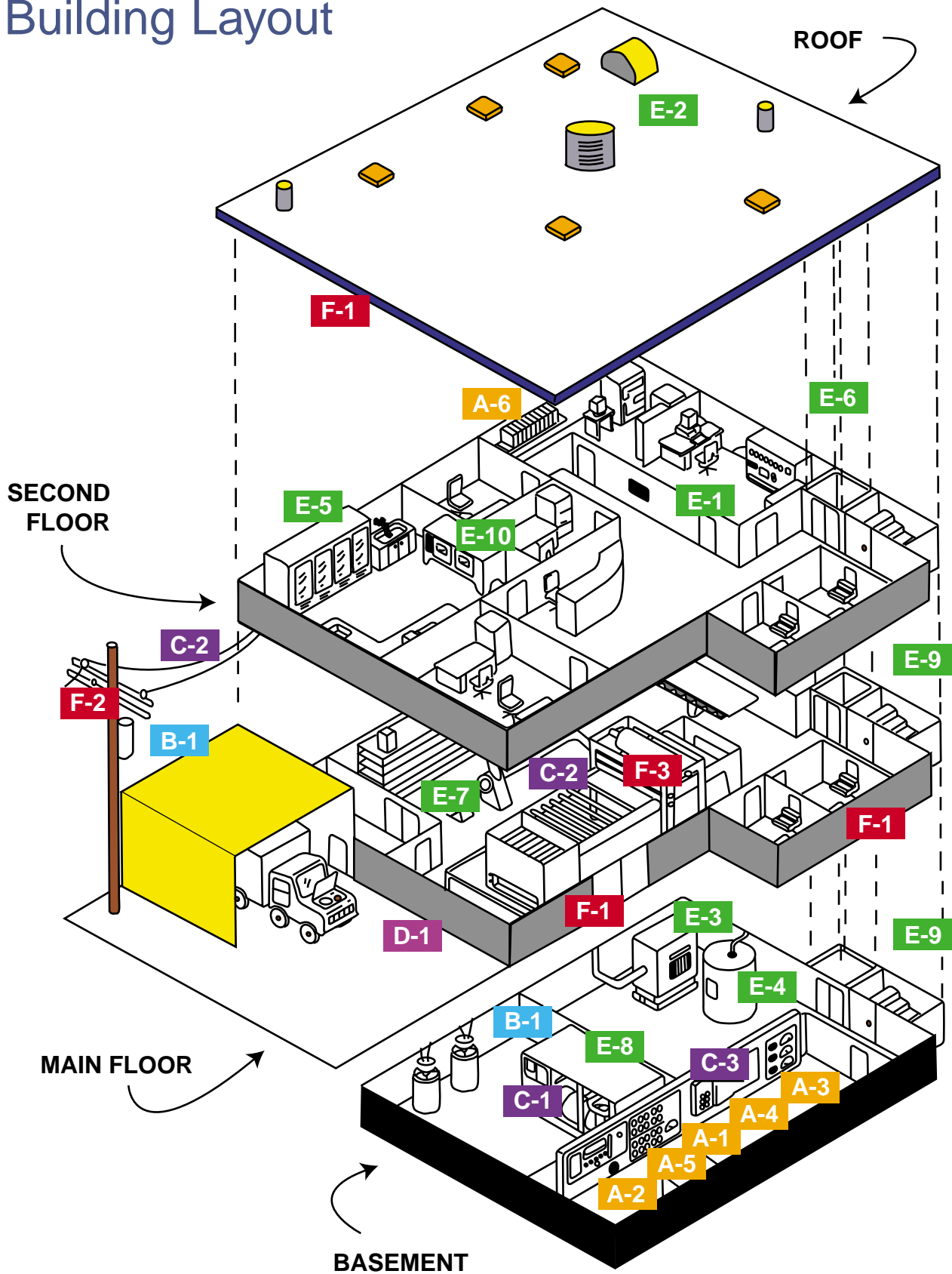

3M™ Infrared Thermometers

Specifications	Models				
	IR-500	IR-750	IR-950	IR-1100	IR-1400
Temperature Range	0 to 500°F (-18 to 260°C)	-25 to 750°F (-32 to 400°C)	-25 to 950°F (-32 to 545°C)	-25 to 1100°F (-32 to 600°C)	-25 to 1400°F (-32 to 760°C)
Accuracy of Reading	±2%	±1%	±1%	±1%	±1%
Repeatability of Reading	±2%	±0.5%	±0.5%	±0.5%	±0.5%
95% Response Time	500 msec	500 msec	500 msec	500 msec	500 msec
Spectral Response	7-18 microns	8-14 microns	8-14 microns	8-14 microns	8-14 microns
Optical System	6:1	12:1	12:1	30:1	50:1
MAX Temperature	–	X	X	X	X
MIN, DIF, AVG Temp	–	–	–	X	X
Recall Last Reading	–	–	–	X	X
Display Hold	X	X	X	X	X
HI Alarm	–	–	–	X	X
LO Alarm	–	–	–	X	X
Low Battery Indicator	X	X	X	X	X
LCD Backlight	X	X	X	X	X
Laser (Class II)	X	X	8 Point Circle	8 Point Circle	8 Point Circle
Emissivity	Pre-set 0.95	Pre-set 0.95	Pre-set 0.95	Adjustable from 0.10 to 1.0	Adjustable from 0.10 to 1.0
Temperature Display	°C or °F selectable 3.5 digit LCD	°C or °F selectable 3.5 digit LCD	°C or °F selectable 3.5 digit LCD	°C or °F selectable 3.5 digit LCD	°C or °F selectable 3.5 digit LCD
Display Resolution	–	0.5°F (0.2°C)	0.5°F (0.2°C)	0.1°F (0.1°C)	0.1°F (0.1°C)
Ambient Operating Range	32 to 120°F (0 to 50°C)	32 to 120°F (0 to 50°C)	32 to 120°F (0 to 50°C)	32 to 120°F (0 to 50°C)	32 to 120°F (0 to 50°C)
Relative Humidity, ambient	10-95% RH noncondensing, @ > 86°F (30°C)	10-95% RH noncondensing, @ > 86°F (30°C)	10-95% RH noncondensing, @ > 86°F (30°C)	10-95% RH noncondensing, @ > 86°F (30°C)	10-95% RH noncondensing, @ > 86°F (30°C)
Storage Temperature	-13° to 158°F (-20° to 60°C) w/out battery	-13° to 158°F (-20° to 60°C) w/out battery	-13° to 158°F (-20° to 60°C) w/out battery	-13° to 158°F (-20° to 60°C) w/out battery	-13° to 158°F (-20° to 60°C) w/out battery
Power	9V Alkaline or NiCd battery	9V Alkaline or NiCd battery	9V Alkaline or NiCd battery	9V Alkaline or NiCd battery	9V Alkaline or NiCd battery
Battery Life (Alkaline)	12 hours	10 hours with laser and backlight on 40 hours with laser and backlight off		20 hours with laser and backlight on 50% 40 hours with laser and backlight off	
Dimensions	7.25 x 1.75 x 1.5 in (184 x 45 x 38 mm)	8 x 6 x 2 in (200 x 160 x 55 mm)	8 x 6 x 2 in (200 x 160 x 55 mm)	8 x 6 x 2 in (200 x 160 x 55 mm)	8 x 6 x 2 in (200 x 160 x 55 mm)
Weight	8 oz. (227g)	11 oz. (320g)	11 oz. (320g)	11 oz. (320g)	11 oz. (320g)
Locking Trigger	–	–	–	X	X
Tripod Mount	–	1/4"-20 UNC Threading	1/4"-20 UNC Threading	1/4"-20 UNC Threading	1/4"-20 UNC Threading
Accessories Standard With Each Unit	–	Hard plastic case Wrist strap	Hard plastic case Wrist strap	Hard plastic case Wrist strap	Hard plastic case Wrist strap
Data Logger Points	–	–	–	12 data points in memory	12 data points in memory

* NIST and DKD certification is optional on all models except the IR-500.

** The IR-60CFO has the same specifications as the IR-60L2 and IR-60EXCFO have the same specifications as the IR-60EXPL2.

*** The IR-1400IS has the same specifications as the IR-1400.



IR-60L2	IR-60EXPL2
-25 to 1600°F (-32 to 870°C)	-25 to 1600°F (-32 to 870°C)
±1%	±1%
±0.5%	±0.5%
250 msec	250 msec
8-14 microns	8-14 microns
60:1	60:1
X	X
-	X
X	X
X	X
X	X
-	X
X	X
X	X
17 Point Circle	17 Point Circle
Adjustable from 0.10 to 1.0	Adjustable from 0.10 to 1.0
°C or °F selectable 3.5 digit LCD	°C or °F selectable 3.5 digit LCD
Tenth degree reading up to 199.9 (F or C)	Tenth degree reading up to 199.9 (F or C)
32 to 120°F (0 to 50°C)	32 to 120°F (0 to 50°C)
10-95% RH noncondensing, @ > 86°F (30°C)	10-95% RH noncondensing, @ > 86°F (30°C)
-25° to 122°F (-30° to 50°C) w/out battery	-25° to 122°F (-30° to 50°C) w/out battery
2 x 1.5V alkaline Type AA	2 x 1.5V alkaline Type AA
25 hours measurement mode, 11 hours with laser on, 6 hours with backlight and laser on (50% backlight used)	
6.7 x 2 x 7.9 in (170 x 50 x 200 mm)	6.7 x 2 x 7.9 in (170 x 50 x 200 mm)
1 lb - 6 oz.	1 lb - 6 oz.
X	X
1/4"-20 UNC Threading	1/4"-20 UNC Threading
Hard plastic case Wrist strap	Software, RS232 cable, 7.5 V power supply, contact probe Hard plastic case, wrist strap
-	100 points in memory



IR-500



IR-750/950



IR-1100/1400/1400IS



IR-60L2/60CFO



IR-60EXPL2/60EXCFO

In your business, power,
technology and reliability are
essential. 3M delivers that
and more.
We have the power of a
diversified, global manufacturer
with more than 60,000 products
in our line; a reputation for
technical excellence and
innovation; and employees
committed to delivering quality
products and service to you, our
valued customer.
Our capability doesn't stop with
electrical products, it starts there.
To explore the many ways we
can serve you, contact your 3M
representative today!

Temperature Technology for the Real World

The 3M family of infrared thermometers provides temperature technology for the real world, combining infrared, laser, microprocessor and LCD display technologies in a rugged package that is simple to use.

3M™ Infrared Thermometers are preventative maintenance tools you can count on, from the simple IR-500 to the advanced IR-60EXPL2. Increased range of temperature measurement, quicker response times and improved optics make these some of the most sophisticated temperature measurement devices available.



WARNING: Not made for taking human temperature. Do not point laser directly at eye or indirectly off reflective surfaces.

Important Notice

Before using this product, you must evaluate it and determine if it is suitable for your intended application. You assume all risks and liability associated with such use.

Warranty; Limited Remedy; Limited Liability.

This product will be free from defects in material and manufacture for a period of one year from date of purchase. 3M MAKES NO

OTHER WARRANTIES INCLUDING, BUT NOT LIMITED TO, ANY IMPLIED WARRANTY OF MERCHANTABILITY OR FITNESS FOR A PARTICULAR PURPOSE. If this product is defective within the warranty period stated above, your exclusive remedy shall be, at 3M's option, to replace or repair the 3M product or refund the purchase price of the 3M product. Except where prohibited by law, 3M will not be liable for any loss or damage arising from this 3M product, whether direct, indirect, special, incidental or consequential regardless of the legal theory asserted.

3M

Electrical Products Division

6801 River Place Blvd.
Austin, TX 78726-9000
800 245 3573
Fax 800 245 0329
<http://www.3M.com/elpd>



40% Pre-consumer waste paper
10% Post-consumer waste paper

Litho in USA.

© 3M IPC 2000 80-6109-4414-4 (0215.0) CSI-2