



O/B⁺ Wire Connector



LISTED
314R

Data Sheet

Application

Use a 3M™ O/B⁺ Wire Connector to electrically connect two or more conductor ends in a pigtail application and insulate the connection.

Wire

AWG Range

COPPER conductors only, No. 22 thru No. 12 sol. and/or str.

METRIC Range

COPPER conductors only, 0,5 mm² thru 2,5 mm² ridged (solid or stranded) and flexible.

(see wire matrix for specific wire combinations)

Construction

Spring

Spring steel, corrosion resistant coating

Insulator

Flame retardant, polypropylene and thermoplastic elastomer, color coded orange/blue

Weight

.0025 lbs. (1,13 gm)

Performance Test

The following tests were performed to the specification of UL Standard 486C and CSA Standard C22.2 No. 188-M1983.

Static-Heating	Pass
Secureness	Pass
Pullout	Pass
Dielectric Voltage Withstand	Pass
Secureness-Of-Insulation	Pass
Flammability	Pass

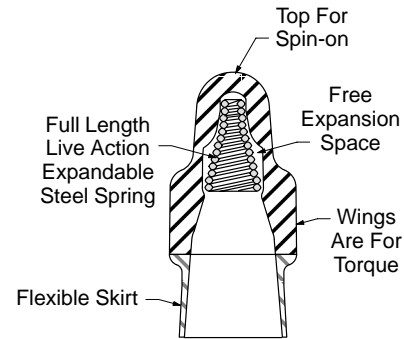
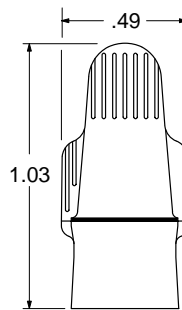

Other Test

Salt Spray	Pass
Per MIL-STD-1344A Method 1001.1	
Vibration	Pass
Per MIL-STD-1344A Method 2005.1	
UV Exposure	Pass
Per ASTM G-53-77	

Fluid Immersion Test

Connectors were immersed in the following chemicals for seven days at 23°C ± 2°C with no affect on appearance or loss of material strength.

Typical Reagents and Materials From ASTM D 543-87 and MIL-STD-1344A

- Acetic Acid
- Acetone
- Detergent Solution, Heavy Duty
- Ethyl Alcohol (95%)
- Ethyl Alcohol (50%)
- Heptane
- Hydrogen Peroxide Solution 28%
- Methyl Alcohol
- Sodium Hydroxide Solution
- Mineral Spirit
- Lubricating Oil

Engineering Specification

3M O/B⁺ wire connector is capable of connecting two or more wires in a pigtail application, in the wire range of No. 22 thru No. 12 AWG solid and/or stranded copper conductors. The connector shall be constructed with an active (live) spring. With a corrosion resistant coating. The connector shall be UL LISTED and CSA Certified as a pressure wire connector. The connector shall be voltage rated 600 volts maximum, building wire, 1000 volts maximum, signs and lighting fixtures (luminaries). The connector shall have a maximum operating temperature of 105°C (221°F).

Regulatory Agencies

UL Listed

as a Pressure Wire Connector tested per UL Standard 486C
UL File No. E23438

OPERATING TEMPERATURE:
105°C (221°F)

VOLTAGE RATING:
600 volts max. building wire
1000 volts max. signs and lighting fixtures (luminaries)

FLAMMABILITY RATING:
UL94 V-2



Underwriters Laboratories
Standard NO. UL 486C
3M File NO. E23438



Canadian Standards
Association
Standard NO. 22.2
NO. 188-M1983
3M File NO. LR15503



IEC Publications
685-1 and 685-2-4
3M File NO. E95240



PASSPORT
TO
EUROPEAN UNION
COUNTRIES

Important Notice to Purchaser:

All statements, technical information and recommendations related to the Seller's products are based on information believed to be reliable, but the accuracy or completeness thereof is not guaranteed. Before utilizing the product, the user should determine the suitability of the product for its intended use. The user assumes all risks and liability whatsoever in connection with such use.

Any statements or recommendations of the Seller which are not contained in the Seller's current publications shall have no force or effect unless contained in an agreement signed by an authorized officer of the Seller. The statements contained herein are made in lieu of all warranties expressed or implied, including but not limited to the implied warranties of merchantability and fitness for a particular purpose which warranties are hereby expressly disclaimed.

SELLER SHALL NOT BE LIABLE TO THE USER OR ANY OTHER PERSON UNDER ANY LEGAL THEORY, INCLUDING BUT NOT LIMITED TO NEGLIGENCE OR STRICT LIABILITY, FOR ANY INJURY OR FOR ANY DIRECT, INDIRECT, INCIDENTAL OR CONSEQUENTIAL DAMAGES SUSTAINED OR INCURRED BY REASON OF THE USE OF ANY OF THE SELLER'S PRODUCTS..



Electrical Products Division

6801 River Place Blvd.
Austin, TX 78726-9000
www.mmm.com/elpd



*Printed on 50% recycled
waste paper; including 10%
post-consumer waste paper.*

Litho in USA
© 3M 1998
78-8121-1125-6